



**TECHNICAL DATA**

Technical data may be updated at any time. It is the users responsibility to check data validity by reference to the website or Nuplex Construction Products

MANUAL SECTION	ISSUE DATE	AUTHORISED	REPLACES	PAGE
Roofing	May 2006	PM	Nov 2005	1 of 4

## SOPREMA SOPRAFIX HP MECHANICALLY FASTENED ROOFING SYSTEM

**DESCRIPTION:**

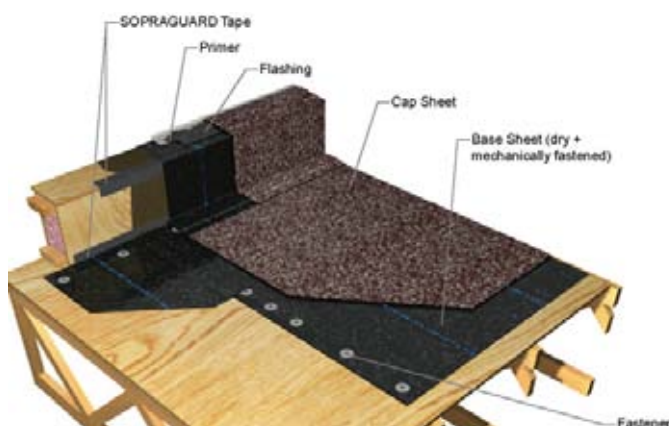

**Sopralene Soprafix HP** insulated roof system is a double layer, combination of a mechanically fixed and torch applied waterproofing system for flat/low pitch roofs. It may be applied with or without insulation.

**Features:**

Mechanically fastened.

Double layer  
Insulation value (if installed)

**Benefits:**

- Independent from substrate movement
- Less subject to joint movement
- Horizontal ventilation under Soprafix is allowed.
- Water tightness integrity
- Combination of ventilation, insulation and soundproofing

**RECOMMENDED**

**USES:**

- Flat/low pitch roofs up to 20% pitch.
- Over concrete, well fixed plywood, old membranes, metal roofs.

**COMPONENTS:**

- a) Insulation  
(If required)
- b) First Layer  
Sopralene Soprafix HP 2.5mm polyester reinforced elastomeric bituminous based membrane (SBS). Soprafix is mechanically fastened with supplied screws/washers.
- c) Second Layer  
Sopralene Flam 180AR 4mm non-woven polyester reinforced elastomeric based membrane.

No warranty either expressed or implied or statutory is made by NUPLEX in this document except as expressly stated in any sale and purchase agreement entered into between NUPLEX and the buyer.

This document is a technical data information sheet The description of the product or products and the properties of the product or products contained in this document is for the sole purpose of identifying the product or products and describing their property or properties and does not constitute a warranty that the product or its properties shall conform to that description; nor is the description of the product and/or its properties a warranty by NUPLEX that the goods are suitable for a particular purpose.

**NUPLEX CONSTRUCTION PRODUCTS**

PO Box 1 2841, Penrose, Auckland Telephone 0-9-579 2029 Fax 0-9-525 3709 www.nuplexconstruction.co.nz email: bpdsales@nuplex.co.nz

<b>H A M I L T O N</b>	<b>PALMERSTON</b>	<b>NORTH WELLINGTON</b>	<b>CHRISTCHURCH</b>
Telephone: 0-7-847 8658	Telephone: 0-6-353 3685	Telephone: 0-4-477 7040	Telephone: 0-3-366 6802
Fax: 0-7-847 3766	Fax: 0-6-353 3632	Fax: 0-4-477 7039	Fax: 0-3-379 0279

**SOPREMA SOPRAFIX** (cont'd)

**SURFACE PREPARATION:**

Soprafix HP (first layer) is mechanically fixed to the substrate. The substrate must be able to firmly fix a screw fitting. The screw type can be varied depending on the substrate. Old substrates must be treated appropriately for its condition eg: old metal tray decks should be cleaned and spot primed.

**INSULATION:**

If required, insulation sheets (2400 x 1200) should be laid over the substrate butted and joints staggered. Spot adhere using suitable polystyrene adhesive. Do not glue the edges together.

**Installation**

**Soprafix Fastening Guide**

		Zone 4						Zone 5					
		Normal 137,9 km/h			Exposed 182,5 km/h			Normal 159,2 km/h			Exposed 210,6 km/h		
<b>Soprafix HPS</b>	Height	P (N/m <sup>2</sup> )	MF/sqm	S (cm)	P (N/m <sup>2</sup> )	MF/sqm	S (cm)	P (N/m <sup>2</sup> )	MF/sqm	S (cm)	P (N/m <sup>2</sup> )	MF/sqm	S (cm)
Main area	10	1575	3.00	37	1890	3	37	2100	3.00	37	2520	3.36	33
Roof edges and exits		2678	3.57	31	3213	4.28	25	3570	4.76	23	4284	5.71	19
Corners		3780	5.04	22	4536	6.05	18	5040	6.72	2 * 33	6048	8.06	2 * 27
Main area	15	1733	3.00	37	2079	3	37	2310	3.08	36	2772	3.70	30
Roof edges and exits		2945	3.93	28	3534	4.71	23	3927	5.24	21	4712	6.28	2 * 35
Corners		4158	5.54	20	4990	6.65	2 * 33	5544	7.39	2 * 30	6653	8.87	2 * 25
Main area	20	1870	3.00	37	2244	3	37	2494	3.33	33	2993	3.99	27
Roof edges and exits		3180	4.24	26	3815	5.09	21	4239	5.65	19	5087	6.78	2 * 32
Corners		4489	5.99	18	5387	7.18	2 * 30	5985	7.98	2 * 27	7182	9.58	2 * 23

**Re above »:** Minimum 3 fastenings per sqm. - Maximum spacing 37 cm. - Minimum spacing 18 cm - \* an additional fixing in the middle of the membrane  
**Roof layout Chart below:** Area 1 is a low wind zone. Area 2 is medium and 3 is high. Roof zones on the top of a multi storey building vary

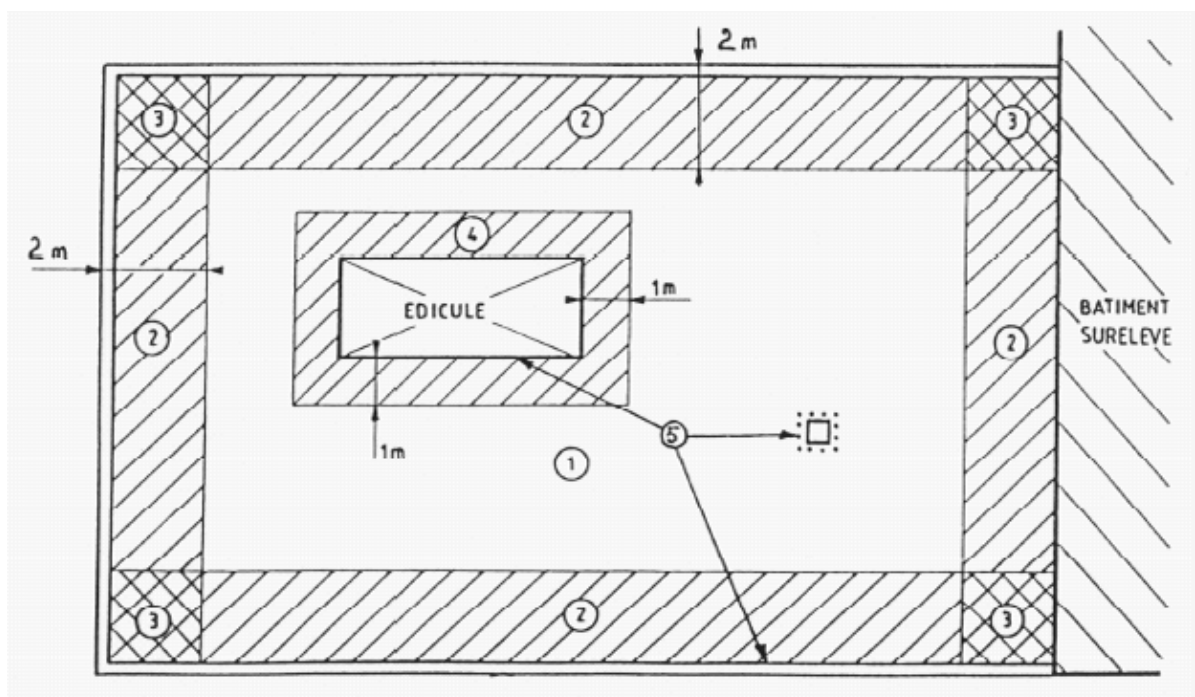

## MEMBRANE:

## INSTALLATION OF THE SOPREMA SOPRAFIX ROOFING SYSTEM

- Install Soprema waterproofing systems strictly in accordance with this specification and technical information supplied by Nuplex and/or Soprema

- Apply minimum 1 coat of Nuplex Membrane Primer to the prepared surface at maximum spread rate of 5-6m<sup>2</sup>/Litre. **Note:** Primer is only required to areas of fully hot torched Soprema

Membrane ie upstands, drains and detail work and is not required under the Soprafix membrane Take great care to protect the Soprema Primer from dirt or foot or vehicular traffic prior to the membrane application.

- **1<sup>st</sup> Layer** – Install Soprema Soprafix HP by mechanically fastening to horizontal surfaces using recommended screws and washers to the plywood substrate. Membrane is to be laid starting at the lowest point. Screws are to be placed mid way between the outer edge and the 1<sup>st</sup> red line on the membrane. Spacing between fastenings shall not be less than 180mm or greater than 370mm (refer to the previous Soprafix chart for recommended spacings and positions of fixings). Additional fasteners can be installed on the intermediate red line where required to resist anticipated wind loadings.

- Hot torch seam all edge and end laps of the Soprema Soprafix. Hot tool chamfer all edges. Provide 100mm wide side laps and 150mm wide end laps.

- Install appropriate Soprema Flam 180 fillets at all upstands, penetrations, and around drains and vents.

- Vents - Install Nuplex roof vents as required over Soprema Flam 180 Fillets. Ensure all enclosed roof spaces are adequately vented.

- Drains - Install Nuplex Surefix drain over Soprema Flam 180 Fillets or other drains as appropriate where specified.

- **2<sup>nd</sup> layer** - Hot torch apply one layer of Soprema Sopralene Flam Unilay Black Slates over first layer of Soprema Soprafix with 80mm wide side laps and 150mm wide end laps starting at lowest point. Include all flashings, penetrations, upstands and detail work. All laps between top and bottom layer membrane are to be staggered.

- Finishing/Upstands - Membrane upstands must be minimum 150mm high or greater to give minimum 115mm overlap of the cladding or flashing. Top edges are to be finished under cladding, into a sawn chase (concrete) or over flashed as appropriate.

- Install Soprema 180-40 plain in all gutters.

- Apply minimum 1 coat of Soprema Cural at a maximum spread rate of 400gms/m<sup>2</sup> over all areas of Sopralene plain or exposed membrane.

### Note the following:

*Falls are to be provided as appropriate:*

*- Roof areas - minimum recommended fall 1:40 (1.5°).*

*- Internal gutters - minimum recommended fall 1:60 (1.0°).*

*- Pond test - Where practical set temporary dams and pond test all horizontal membranes with water at an appropriate depth for not less than 48 hours. Any failure is to be repaired and the pond test repeated.*

## MAINTENANCE

Where appropriate Soprema Membranes are to be cleaned and maintained as per the Nuplex Soprema Cleaning Maintenance recommendations.

**R VALUE CHART:**  
(if added insulation)

<b>'H' GRADE POLYSTYRENE THICKNESS</b>	<b>R VALUE</b>
40mm	1.0
60mm	1.5
80mm	2.0
100mm	2.5
120mm	3.0

Note: No added value for other components of roofing system.

**WARRANTY:**

The Soprafix HP system complies with the 15 year roofing requirement of the NZ Building Code. A material and specification warranty is provided.

